

We have above **25 years'** experiences on producing packaging machines.

冠榮在生產包裝機械上，擁有超過**25年**以上的豐富經驗

AUTOMATIC PACKAGING MACHINERY EQUIPMENT

自動包裝設備

High Quality 高品質
High Efficiency 高效率
High Service 重視售後服務
Customized Design 可客製化設計



Guan Qi Machinery Co., Ltd. 冠榮機械有限公司

📍 No. 12-9, Shang-Yi, Dapi Township, Yunlin County 63142, Taiwan
63142雲林縣大埤鄉尚義村尚義12-9號

☎ Tel: +886-5-5910-079

📠 Fax: +886-5-5910-123

✉ Email: sales@gqpack.com

🌐 Website: www.gqpack.com

Made in Taiwan 台灣製造



Website



Online Video



Guan Qi Machinery Co., Ltd.
冠榮機械有限公司



About GQ PACK 關於冠榮

Guan Qi Machinery Co., Ltd. (GQ PACK) specialize in producing automatic packaging machines, incl. plastic cup (paper cup) packaging machine, hardware parts packaging machine, sleeve type sealer, bag inserter, etc.

We have rich experiences and many patents on packaging machines. We offer not only the automatic packaging machines in high quality and efficiency but also reliable after-sales service. Besides, we are flexible to customize and design the automatic packaging procedures and machines of the production lines according to the customers' requirement.

All of our products are Made in Taiwan.

冠榮機械有限公司專精在生產全自動包裝機械，生產之項目涵蓋塑膠杯(紙杯)包裝機、五金零件包裝機、袖口式包裝機、紙箱套袋機、開盒機等。

我們的生產經驗豐富，擁有多項專利，專為客戶提供高品質和高效率的全自動包裝機械，重視售後服務，可依照客戶需求，設計規劃整廠生產線的自動化包裝流程和設備。

本公司產品皆為台灣製造。

We can provide the below to customers:

- High quality machines to increase production efficiency, effectively reduce manpower, reduce labor costs and reduce consumables worn out.
- Professional installation to make sure machines working smoothly and connecting to production lines successfully.
- Complete personnel training: Incl. operation instruction, preventive maintenance, troubleshooting, consumables change, etc.
- Reliable after-sales service: Incl. 1 year warranty, telephone support, spare parts supply, installation on site, etc.
- Professional design and suggestion on automatic packaging machines and procedures.
- Customized design: According to customers' specific request, provide the appropriate automatic packaging solutions.
- Continuously upgrade machines performance.

我們可以為客戶提供：

- 高品質的機台：提升生產效率，有效精減人力，降低人力成本，降低耗材損耗。
- 專業的裝機協助，確保機台操作順暢，順利連線。
- 完整的人員教育訓練：含操作指導、預防性維護保養、問題排除、更換耗材指導等。
- 可靠的售後服務：含一年保固、電話支援、到廠維修服務、舊機翻新服務、零件供應等。
- 專業的自動化生產設備和流程規劃與設計。
- 客製化設計：因應客戶產業需求，確實達成自動化包裝。
- 不斷精進提升的機台性能。

After-Sales Service 售後服務



Application Index 包裝應用索引



GQP200 Plastic Cup (Paper Cup) Packaging Machine 塑膠杯(紙杯)包裝機

- Food service disposables: For disposable food containers, such as plastic cups (bowls), paper cups (bowls), Styrofoam cups (bowls), plastic trays (plates, boxes), paper trays (plates, boxes), Styrofoam trays (plates, boxes), cup lids, etc.
- Rectangular stuff: Such as filters, cloth, steel (aluminum) tubes, etc.
- 免洗杯碗和餐盒：如塑膠杯碗、紙杯碗、保麗龍杯碗、塑膠餐盤(餐盒)、紙餐盤(餐盒)、保麗龍餐盤(餐盒)、杯蓋等裝食物用一次性容器。
- 長條形物品：如濾心、布匹、鐵(鋁)管等。



GQSP300 Hardware Parts Packaging Machine (For Small Package) 五金零件包裝機

- Hardware parts: For hardware parts in small packages, such as screws, nuts, couplings, etc.
- 五金零件：如螺絲、螺帽、接頭等小包裝需求的五金零件。



GQC1200 Bag Inserter (Contrary Insert) 紙箱套袋機(反套)

- Big volume of materials to be loaded into bag and carton: Such as screws and other hardware parts, vegetables, etc.
- 大量物品須套袋裝箱：如螺絲等五金零件、蔬菜等。



GQS900 Sleeve Type Sealer 袖口式包裝機

- Bottles and Cans: Such as cola, soda, juice, mineral water, coffee, fruit cans, etc.
- 瓶罐：如可樂、汽水、果汁、礦泉水、咖啡、水果罐頭等。



GQBE501 Box Erector 開盒機

- Boxes: Incl. products arranging, box erecting, products in-feeding and box closing.
- 紙盒：含整列、開盒、入盒、封盒。



GQSH2000, GQSH1500 Shrink Tunnel 收縮機

- Various products that are wrapped with PE or POF shrinkable film.
- 適用於使用PE、POF膠膜做收縮包裝的各種產品。



GQCE6701 Vertical Type Carton Erector 立式開箱機 GQCS6605S Semi-Auto Carton Folding Sealer 半自動折蓋封箱機

- Cartons: Incl. carton erecting, folding, sealing.
- 紙箱：含開箱、折蓋、封箱。



GQW101, GQW103, GQW104, GQW105 Pallet Wrapper 棧板膠膜裹包機

- Pallet wrapping.
- 棧板裹包。

GQP200

Plastic Cup (Paper Cup) Packaging Machine 塑膠杯(紙杯)包裝機



Online Video

Application

- This machine is suitable for packaging disposable paper cups (bowls) / plastic cups (bowls), cup lids, hardware, medicinal, round / rectangular / square products and foodstuffs.

Key Features

- The side sealing uses constant-temperature sealing rollers so that the sealing is tight.
- Easy to operate.
- Fast sealing.
- No waste on film.
- Applicable packaging film includes POF, PE, CPP, OPP, PP and so on.
- Controlled by touch screen (HMI / MMI).
- It can either memorize 25 sets of packing parameters or automatically detect the packing length.
- Alarm indicator for abnormal warning.
- Optional: safety cover.

用途

- 本機適用於紙杯(碗)、塑膠杯(碗)、杯蓋、五金、藥品、圓形、長條型、四角型、食品類產品包裝用。

特性

- 本機側封口採用封切輪恆溫封口包裝，使封口牢固。
- 操作簡單，使用便利。
- 封口快速。
- 無膠膜殘料。
- 適用的包裝膠膜含POF、PE、CPP、OPP、PP等。
- 觸控式螢幕(人機介面)操控。
- 可記憶25組包裝物參數或是可自動偵測包裝長度(2擇1)。
- 警示燈異常警示。
- 機台可加裝安全罩，費用另計。

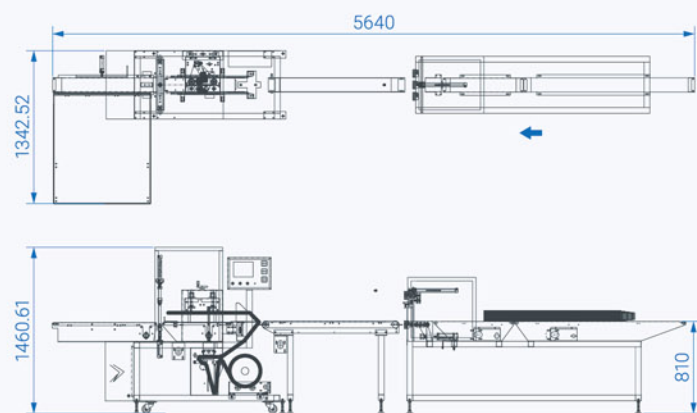

Machine Size	Sealing Size	Packing Size	Working Height	Packing Capacity	Voltage
機械尺寸	封口尺寸	包裝尺寸	工作高度	包裝速度	電壓
L3100 × W650 × H1450 mm Spec. subject to change without prior notice. 機台尺寸以實際製作為準	200 mm	Ø60~115 mm	810 mm	10~15 packs/min	1Φ, 220V Depend on customer's request. 可依客戶需求指定

GQSP300

Hardware Parts Packaging Machine (For Small Package) 五金零件包裝機



Online Video

Application

- This machine is suitable for packaging screws, hardware and small parts.

Key Features

- The constant-temperature sealing makes the sealing tight.
- Easy to operate.
- Fast sealing.
- No waste on film.
- Applicable packaging film includes PE, CPP, OPP, PP and so on.
- Controlled by touch screen (HMI / MMI).
- It can memorize 25 sets of packing parameters.
- Alarm indicator for abnormal warning.
- It can pack in 1~5 packs/string.

用途

- 本機適用於螺絲、五金、小零件等產品包裝用。

特性

- 本機封口採用恆溫封口包裝，使封口牢固。
- 操作簡單，使用便利。
- 封口快速。
- 無膠膜殘料。
- 適用的包裝膠膜含PE、CPP、OPP、PP等。
- 觸控式螢幕(人機介面)操控。
- 可記憶25組包裝物參數。
- 警示燈異常警示。
- 可連續成串包裝1~5包/串。

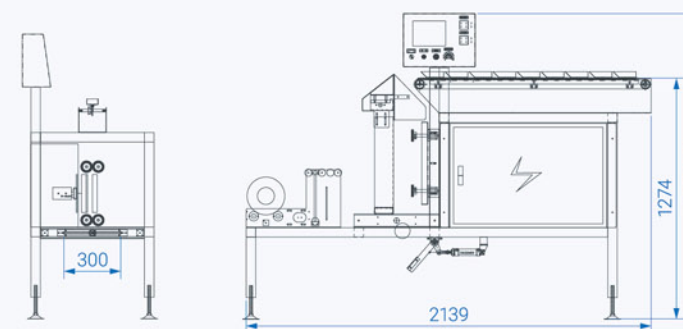
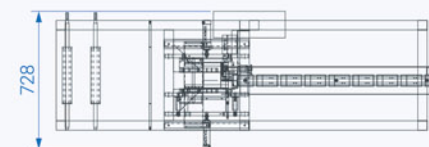

Machine Size	Sealing Size	Packing Size	Packing Capacity	Voltage
機械尺寸	封口尺寸	包裝尺寸	包裝速度	電壓
L2139 × W728 × H1613 mm Spec. subject to change without prior notice. 機台尺寸以實際製作為準	300 mm	L60~200 × W40~100 mm	10~18 packs/min	1Φ, 220V Depend on customer's request. 可依客戶需求指定

GQC1200

Bag Inserter (Contrary Insert)
紙箱套袋機(反套)



Online Video

Application

- This machine is suitable for packaging hardware, screws, etc.

Key Features

- Easy adjustment for various carton sizes.
- It can be connected with different peripheral equipments.
- Easy to operate and adjust.
- Applicable for diversity of products packaging.
- It can be connected to conveyors for automatically feed and output.
- Controlled by touch screen (HMI / MMI).

用途

- 本機適用於五金類、螺絲等產品包裝用。

特性

- 配合開箱尺寸。
- 可配合周邊設備。
- 操作簡單，容易調整。
- 適用於多樣化產品包裝。
- 可連接輸送機自動送料。
- 觸控式螢幕(人機介面)操控。

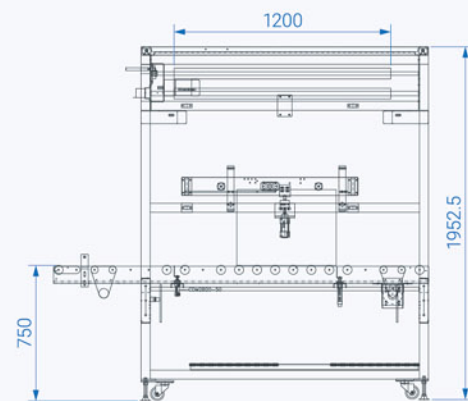
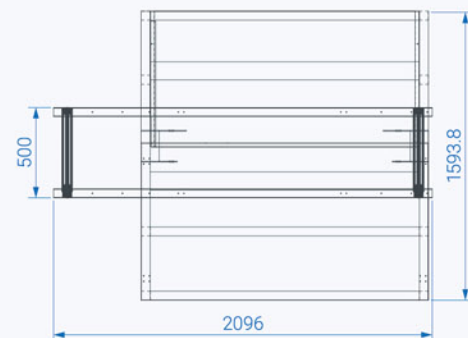
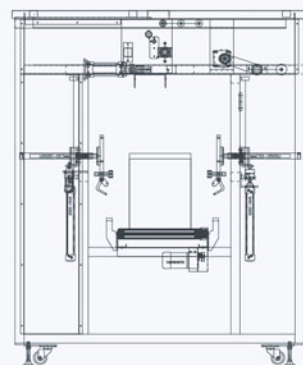

Machine Size	Sealing Size	Carton Size	Working Height	Packing Capacity	Voltage
機械尺寸	封口尺寸	包裝尺寸	工作高度	包裝速度	電壓
L2650 × W1660 × H2000 mm Spec. subject to change without prior notice. 機台尺寸以實際製作為準	1200 mm	L500 × W350 × H400 mm	750 mm	1~10 cartons/min	3Φ, 380V Depend on customer's request. 可依客戶需求指定

GQS900

Sleeve Type Sealer
袖口式包裝機



Online Video

Application

- This machine is suitable for alignment and packaging of bottles and cans.

Key Features

- The constant-temperature sealing makes the sealing tight.
- Easy to operate.
- Packaging size can be adjusted according to various spec. of bottles and cans.
- Applicable packaging film: PE.

用途

- 本機適用於瓶罐整列、包裝。

特性

- 本機封口採用恆溫封口包裝，使封口牢密。
- 操作簡單，使用便利。
- 可配合各式規格的瓶罐作包裝調整。
- 本機適用PE膠膜包裝。

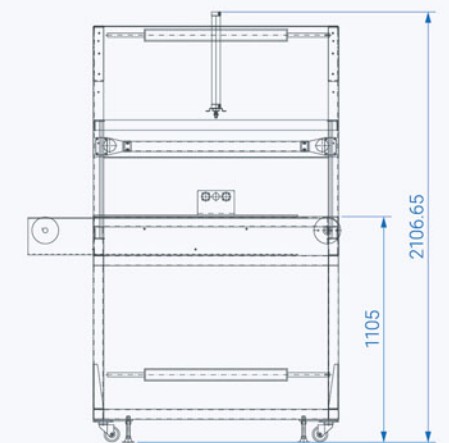
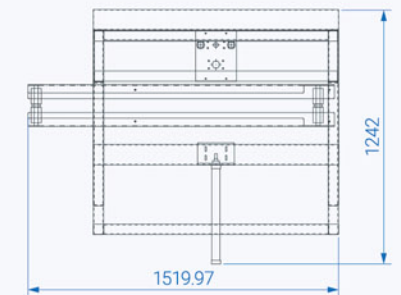
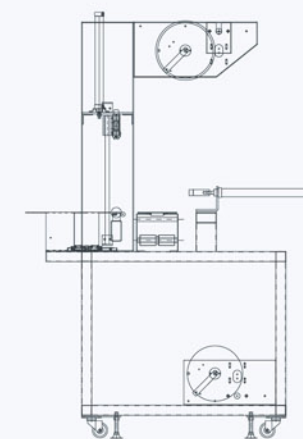

Machine Size	Sealing Size	Packing Size	Packing Capacity	Voltage
機械尺寸	封口尺寸	包裝尺寸	包裝速度	電壓
L3540 × W1330 × H2380 mm Spec. subject to change without prior notice. 機台尺寸以實際製作為準	900 mm	L420 × W280 × H180 mm	10~12 packs/min	3Φ, 220V Depend on customer's request. 可依客戶需求指定

GQBE501 / Box Erector 開盒機



Application

- This machine is suitable for box packaging of various products, incl. products arranging, box opening, box erecting, products in-feeding, and box closing at a time.

Key Features

- Automatic box erector without using hotmelt.
- Controlled by touch screen (HMI / MMI).
- Easy to operate.
- Automatic products arranging, box opening, box erecting, products in-feeding, and box closing at a time.
- Automatic box erector could be customized according to various boxes sizes.

用途

- 本機適用於各種產品的紙盒包裝，含整列、開盒、入盒、封盒。

特性

- 本機採用紙盒自動成型包裝，不需熱熔膠。
- 觸控式螢幕(人機介面)操控。
- 操作簡單，使用便利。
- 全自動整列、開盒、入盒、封盒。
- 可因應不同的紙盒尺寸，客製化開盒機。

Machine Size	Box Size	Cardboard Storage	Working Height	Packing Capacity	Voltage
機械尺寸	紙盒尺寸	紙盒儲存數	工作高度	包裝速度	電壓
L4070 × W760 × H1620 mm Spec. subject to change without prior notice. 機台尺寸以實際製作為準	L145 × W95 × H45 mm	450 pcs	910 mm	10~15 boxes/min	3Φ, 220V Depend on customer's request. 可依客戶需求指定

GQSH2000 / Shrink Tunnel GQSH1500 / 收縮機



Application

- This machine is suitable for various products that are wrapped with PE or POF shrinkable film.

Key Features

- Easy to operate.
- It can be connected with different peripheral equipments.
- The speed can be adjusted.
- The shaft of the conveyor could be changed to the optional dense chain for small stuff.

用途

- 本機適用於使用PE、POF膠膜做收縮包裝的各種產品。

特性

- 操作簡單，使用便利。
- 可配合周邊設備。
- 速度可調整。
- 輸送帶軸心可選購改用密集式，以便收縮包裝體積小的物品。

Machine Size			Tunnel Size	
機械尺寸			爐口尺寸	
GQSH2000: L2600 × W760 × H1430 mm GQSH1500: L2400 × W960 × H1880 mm Spec. subject to change without prior notice. 機台尺寸以實際製作為準			GQSH2000: L2000 × W450 × H250 mm GQSH1500: L1500 × W600 × H400 mm	
Packing Size	Applicable Film	Conveyor Speed	Heating	Voltage
包裝尺寸	適用膠膜	輸送速度	電熱	電壓
GQSH2000: W290 × H150 mm GQSH1500: W420 × H300 mm	PE, POF	2~12 M/min	24 KW	3Φ, 220V Depend on customer's request. 可依客戶需求指定

GQCE6701

Vertical Type Carton Erector 立式開箱機



Online Video

Application

- This machine is suitable for automatic packaging lines, include carton opening, erecting, folding bottom flaps and sealing at a time.

Key Features

- Vertical type carton erector. Manually refill unopened cardboards at any time.
- Side belt driven.
- Applicable to common cartons. Used for automatic packaging lines, include carton opening, erecting, folding bottom flaps and tape sealing at a time.
- PLC controlled. Easy to alter the program.
- Controlled by touch screen (HMI / MMI).
- Easy to adjust for different carton sizes by handwheel.

- Adhesive tape seat can automatically adjust for uneven cartons, which is fast, smooth and durable.
- Japanese pneumatic components.
- Safety signal and shortage alarm of cardboard storage.
- Brush wipe down makes bottom tape sealing smooth.
- Dual suction cups.
- Easy to operate.

用途

- 本機適用於自動化包裝生產線，開箱、成型、折底蓋封箱一次完成。

特性

- 全自動立式開箱機，隨時可補充未開之紙箱。
- 兩側皮帶驅動。
- 適用於一般常見紙箱類型，配合自動化系統，開箱、成型、折底蓋封箱一次完成。
- PLC系統控制。
- HMI人機介面控制。
- 附有操作手把，手動輕鬆調整開箱紙箱尺寸。
- 貼帶座新型設計，可自動調整紙箱之不平，快速平整耐用度高。
- 採用日製氣壓元件。
- 備有安全訊號裝置及儲箱槽無料訊號裝置。
- 搭配刷片，使底部封箱膠帶更平整漂亮。
- 雙吸盤開箱機構。
- 安裝容易，操作簡單。

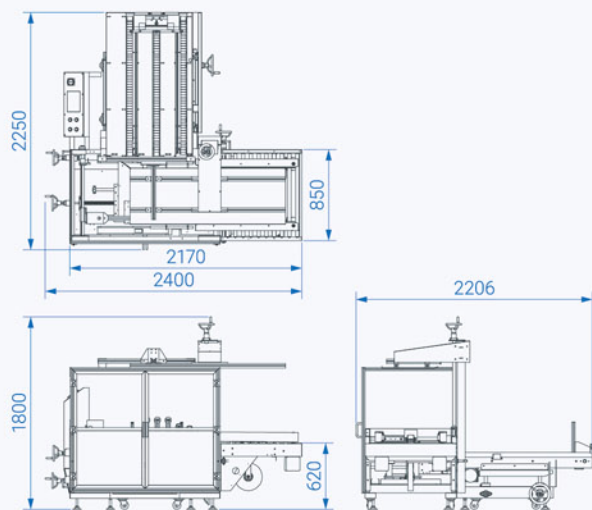

Machine Size	Driven	Tape Width	Feeding Direction	Carton Size
機械尺寸	傳動方式	膠帶寬度	儲箱槽方向	可開箱尺寸
L2310 × W2400 × H1800 mm Spec. subject to change without prior notice. 機台尺寸以實際製作為準	By Side Belt 兩側皮帶驅動	2" or 3"	L Type Left Hand / Right Hand 左向 / 右向	L250~500 mm W170~400 mm H90~500 mm
Tape Overlap	Working Height	Capacity	Cardboard Storage	Voltage
膠帶前後貼	工作高度	開箱速度	儲箱槽數量	電壓
L60±5 mm	650 mm	8~10 cartons/min Depend on carton's size and material. 依據紙箱之材料、尺寸而定	90~100 pcs Depend on carton's thickness. 依紙箱厚度而增減	3Φ, 220V Depend on customer's request. 可依客戶需求指定

GQCS6605S

Semi-Auto Carton Folding Sealer 半自動折蓋封箱機

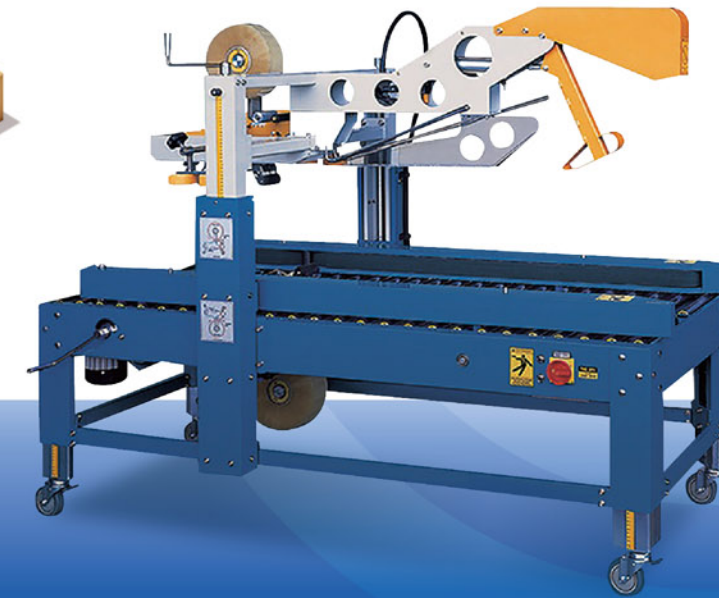

Online Video

Application

- This machine is suitable for automatic packaging lines, include top flaps folding and sealing at a time.

Key Features

- Side belt driven.
- Pneumatic top flaps folding, include front, side and rear flaps, and tape sealing at a time. Used for automatic packaging lines.
- Semi-Auto. Easy to adjust for different carton sizes by crank handle.
- Applicable to the production lines in uniform and lightweight cartons.
- Side clip-rollers make the carton sealing tight.

- Working height can be adjusted among H570~770 mm according to the front and the rear conveyors.
- Flexible top adhesive tape seat can automatically adjust for uneven cartons, which is fast, smooth and durable.
- Locking casters.
- Easy to operate.

用途

- 本機適用於自動化包裝生產線，自動折上蓋、封箱一次完成。

特性

- 兩側皮帶驅動。
- 自動折上蓋，採汽缸動作，平穩順暢，封箱作業一氣呵成，省時省力，可配合自動化包裝系統使用。
- 半自動機種，附有調整手把，根據紙箱尺寸手動調整輕鬆容易。
- 適合紙箱尺寸單純生產線。適合裝載較輕產品。
- 兩側補助夾輪設計，使封箱密合度佳。
- 工作高度可配合前後輸送機作調整 (H570~770 mm)。
- 上貼帶座彈性設計，可自動調整紙箱之不平，快速平整，耐用度高。
- 剎車腳輪。
- 簡易操作。

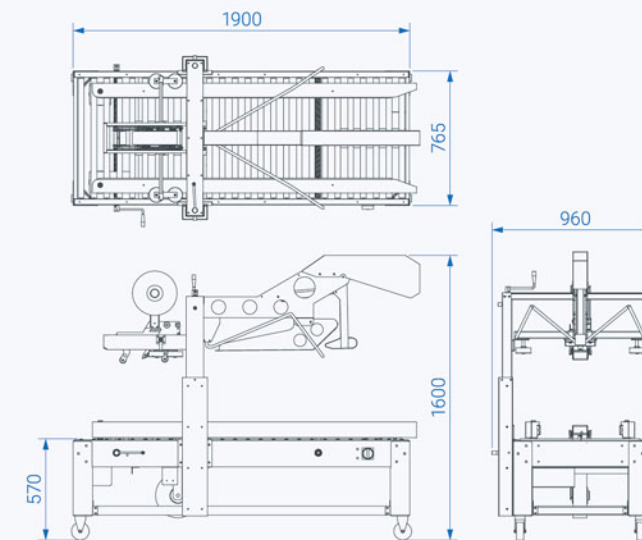

Machine Size	Driven	Tape Width	Conveyor Speed	
機械尺寸	傳動方式	膠帶寬度	輸送速度	
L1900 × W960 × H1600 mm Spec. subject to change without prior notice. 機台尺寸以實際製作為準	By Side Belt 兩側皮帶驅動	2" or 3"	20 M/min	
Tape Overlap	Working Height	2" Tape Sealing Size	3" Tape Sealing Size	Voltage
膠帶前後貼	工作高度	2" 可封箱尺寸	3" 可封箱尺寸	電壓
L60±5 mm	570~770 mm	L200~600 mm W135~500 mm W120~500 mm	L200~600 mm W150~500 mm W120~500 mm	3Φ, 220V Depend on customer's request. 可依客戶需求指定

GQW101

Automatic Stretch Wrapper 全自動預拉膠膜機

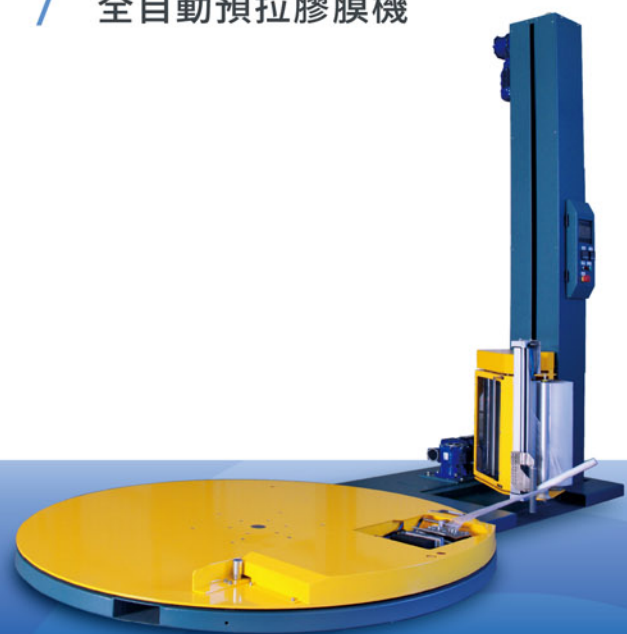

Online Video

Key Features

- PLC with the inverter controls motor.
- Patented clamp-film / stick-film mechanism for automatic process to reduce working time.
- Remote start to save the operator's time to go back and forth from the forklift.
- It can stick the film tails directly. The film tails won't peel off and the wrapping finishing is tight and tidy.
- The turntable is driven by the belt, which makes it turning in no noise, stable and smooth.

- The film carriage has the patented anti-drop device to ensure safety.
- The speed of the turntable and the film carriage can be adjusted by the inverter.
- The turntable has soft start / stop to ensure safety.
- Fast film loading.
- The turntable can be positioned to the origin automatically.
- It can be switched to manual or auto mode.
- Controlled by touch screen (HMI / MMI).

特性

- PLC 程式控制，搭配變頻器控制馬達。
- 專利夾膜/黏膜機構，流程自動化，縮短作業時間。
- 遙控啟動，省下操作人員往返堆高機時間。
- 機器黏膜，膜尾在運送中不易脫落，裹包緊實又整潔。
- 皮帶式轉盤傳動，轉動無噪音、平穩順暢。
- 專利防墜裝置，保障使用安全。
- 轉盤及膠膜座速度，可無段變頻調整。
- 轉盤具和緩啟動/停止功能，確保產品安全。
- 膠膜快速穿膜設計。
- 轉盤具原點定位功能。
- 可切換手動/自動操作模式。
- 觸控式面板控制。

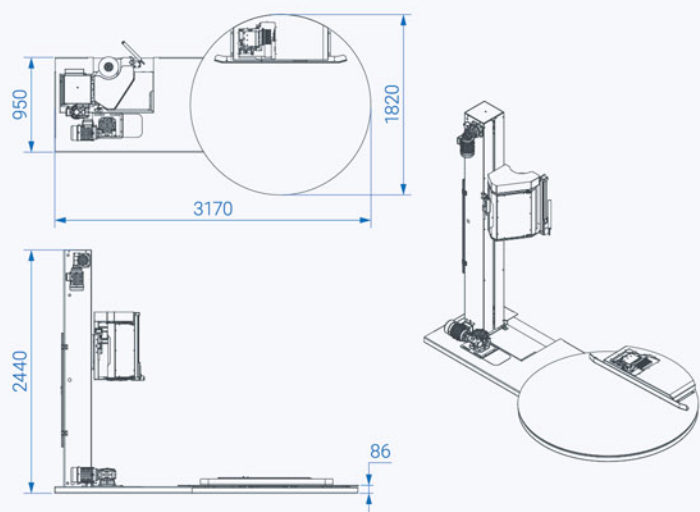

Machine Size	Turntable Dia.	Turntable Height	Optional	Applicable Film	
機械尺寸	轉盤直徑	轉盤高度	選配	適用膠膜	
L3220 × W1810 × H2440 mm Spec. subject to change without prior notice. 機台尺寸以實際製作為準	1800 mm Optional: Customized size is available. 可訂製加大	86 mm	Ramp 斜拖板	PE 20~30μ	
Film Pre-Stretch	Max. Load Weight	Max. Wrap Height	Film Carriage Speed	Turntable Speed	Voltage
膠膜預拉	乘載重量	裹包高度	昇降速度	轉盤速度	電壓
200% Standard. 標準	1500 kg Optional: 2000 kg 可選購：2000 kg	2000 mm	3 M/min Adjustable. 可調	12 RPM Adjustable. 可調	1Φ, 220V Depend on customer's request. 可依客戶需求指定

GQW103

Standard Stretch Wrapper 標準預拉膠膜機

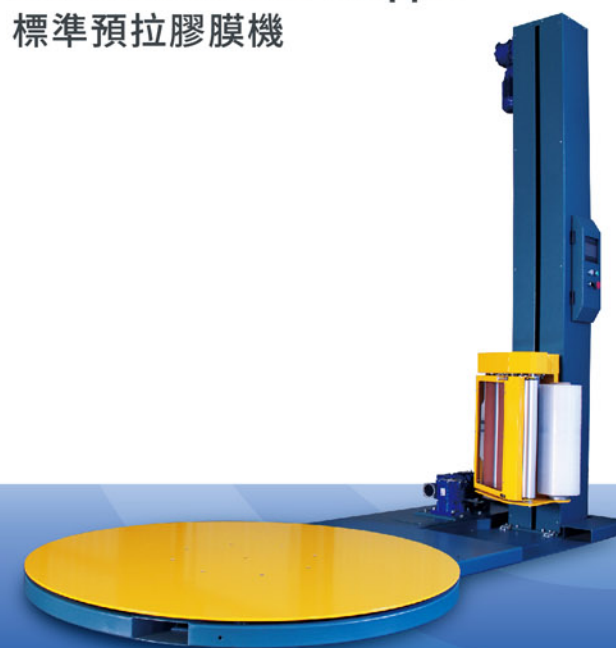

Online Video

Key Features

- PLC with the inverter controls motor.
- The turntable is driven by the belt, which makes it turning in no noise, stable and smooth.
- The film carriage has the patented anti-drop device to ensure safety.
- The speed of the turntable and the film carriage can be adjusted by the inverter.

- The turntable has soft start / stop to ensure safety.
- Fast film loading.
- It can be switched to manual or auto mode.
- Controlled by control panel.
- The sensor detects the packing height automatically.

特性

- PLC 程式控制，搭配變頻器控制馬達。
- 皮帶式轉盤傳動，轉動無噪音、平穩順暢。
- 專利防墜裝置，保障使用安全。
- 轉盤及膠膜座速度，可無段變頻調整。
- 轉盤具和緩啟動/停止功能，確保產品安全。
- 膠膜快速穿膜設計。
- 可切換手動/自動操作模式。
- 操作面板控制。
- 電眼自動偵測包裝物高度。

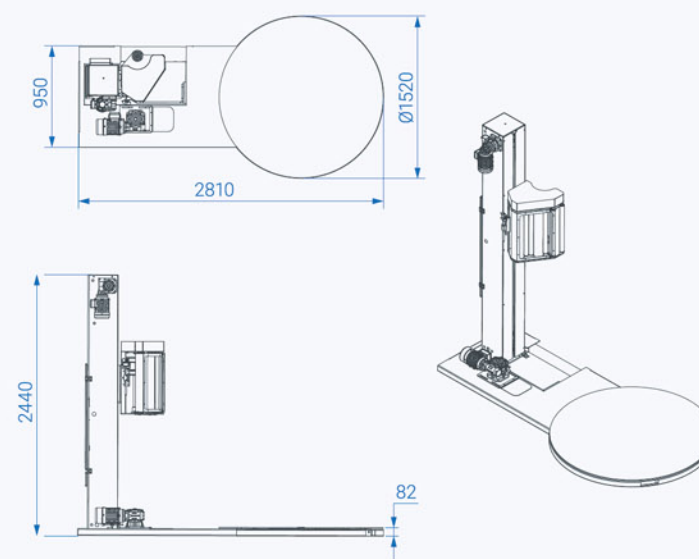

Machine Size	Turntable Dia.	Turntable Height	Optional	Applicable Film	
機械尺寸	轉盤直徑	轉盤高度	選配	適用膠膜	
L2820 × W1520 × H2440 mm Spec. subject to change without prior notice. 機台尺寸以實際製作為準	1500 mm Optional: Customized size is available. 可訂製加大	82 mm	Ramp 斜拖板	PE 20~30μ	
Film Pre-Stretch	Max. Load Weight	Max. Wrap Height	Film Carriage Speed	Turntable Speed	Voltage
膠膜預拉	乘載重量	裹包高度	昇降速度	轉盤速度	電壓
200% Standard. 標準	1500 kg Optional: 2000 kg 可選購：2000 kg	2000 mm	3 M/min Adjustable. 可調	12 RPM Adjustable. 可調	1Φ, 220V Depend on customer's request. 可依客戶需求指定

GQW104

Semi-Auto Wrapper (Electronic) 半自動無預拉膠膜機(電子張力調整)

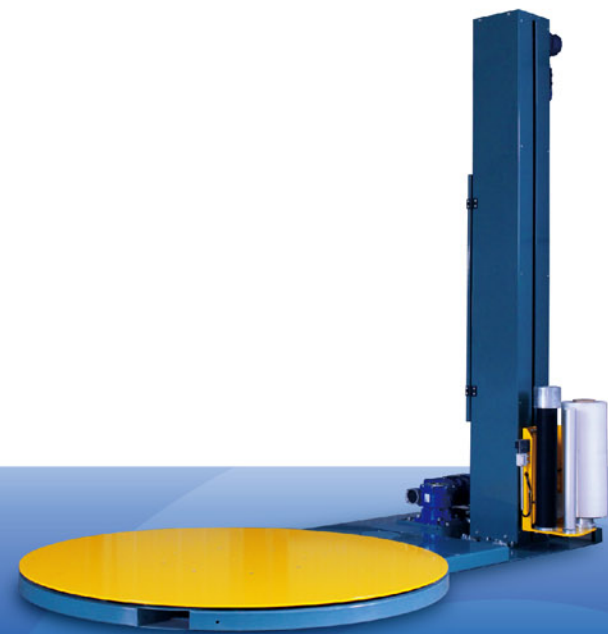

Online Video

Key Features

- PLC with the inverter controls motor.
- The turntable is driven by the belt, which makes it turning in no noise, stable and smooth.
- The film carriage has the patented anti-drop device to ensure safety.
- The speed of the turntable and the film carriage can be adjusted by the inverter.
- The turntable has soft start / stop to ensure safety.
- It can be switched to manual or auto mode.
- Controlled by control panel.
- The sensor detects the packing height automatically.
- Electronically adjust the tension and the tightness of the stretch film.
- Manually fix the film to the pallet first and then turn on the wrapper.
- Separate 1~9 top and bottom wrap count is adjustable.

特性

- PLC程式控制，搭配變頻器控制馬達。
- 皮帶式轉盤傳動，轉動無噪音、平穩順暢。
- 專利防墜裝置，保障使用安全。
- 轉盤及膠膜座速度，可無段變頻調整。
- 轉盤具和緩啟動/停止功能，確保產品安全。
- 可切換手動/自動操作模式。
- 操作面板控制。
- 電眼自動偵測包裝物高度。
- 電子式張力調整，可無段調整伸縮膜鬆緊度。
- 需手動將膠膜固定到棧板上再啟動。
- 上下裹包圈數：1~9圈可調整。

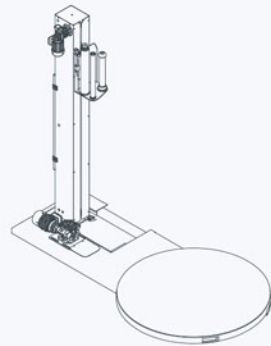
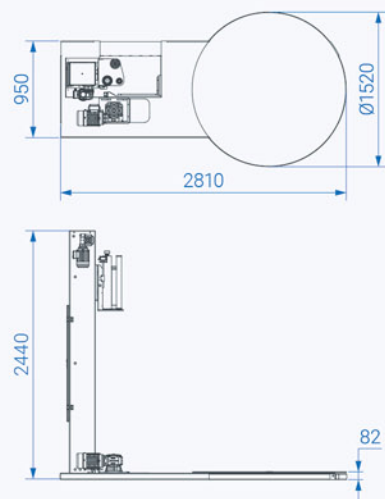

Machine Size	Turntable Dia.	Turntable Height	Optional	Applicable Film
機械尺寸	轉盤直徑	轉盤高度	選配	適用膠膜
L2820 × W1520 × H2440 mm Spec. subject to change without prior notice. 機台尺寸以實際製作為準	1500 mm Optional: Customized size is available. 可訂製加大	82 mm	Ramp 斜拖板	PE 20~30μ
Max. Load Weight	Max. Wrap Height	Film Carriage Speed	Turntable Speed	Voltage
乘載重量	裹包高度	昇降速度	轉盤速度	電壓
1500 kg Optional: 2000 kg 可選購：2000 kg	2000 mm	3 M/min Adjustable. 可調	12 RPM Adjustable. 可調	1Φ, 220V Depend on customer's request. 可依客戶需求指定

GQW105

Semi-Auto Wrapper (Mechanical) 半自動無預拉膠膜機(機械張力調整)

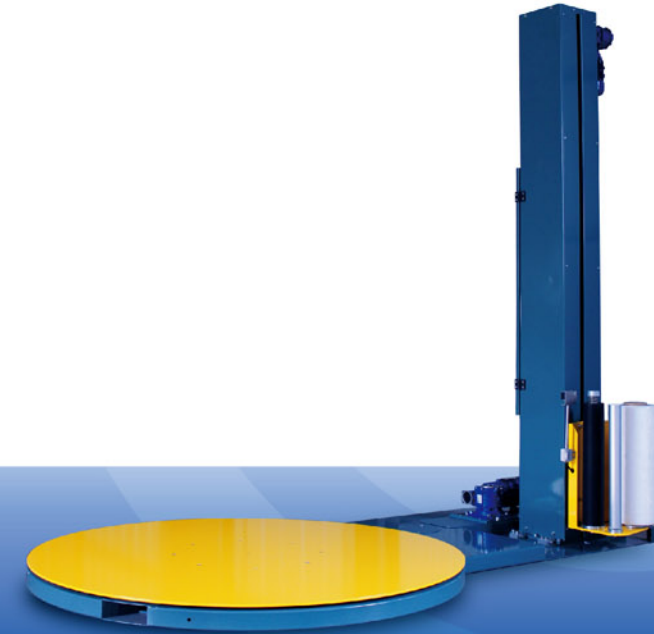

Key Features

- PLC with the inverter controls motor.
- The turntable is driven by the belt, which makes it turning in no noise, stable and smooth.
- The film carriage has the patented anti-drop device to ensure safety.
- The speed of the turntable and the film carriage can be adjusted by the inverter.
- The turntable has soft start / stop to ensure safety.
- It can be switched to manual or auto mode.
- Controlled by control panel.
- The sensor detects the packing height automatically.
- Mechanically adjust the tension. Manually rotate to adjust the tightness of the stretch film.
- Manually fix the film to the pallet first and then turn on the wrapper.
- Separate 1~9 top and bottom wrap count is adjustable.

特性

- PLC程式控制，搭配變頻器控制馬達。
- 皮帶式轉盤傳動，轉動無噪音、平穩順暢。
- 專利防墜裝置，保障使用安全。
- 轉盤及膠膜座速度，可無段變頻調整。
- 轉盤具和緩啟動/停止功能，確保產品安全。
- 可切換手動/自動操作模式。
- 操作面板控制。
- 電眼自動偵測包裝物高度。
- 機械式張力調整，以手動旋轉方式調整膠膜鬆緊度。
- 需手動將膠膜固定到棧板上再啟動。
- 上下裹包圈數：1~9圈可調整。

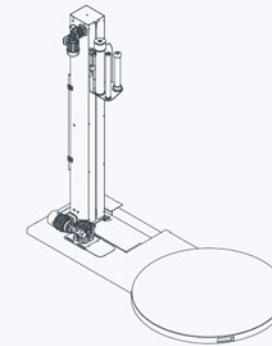
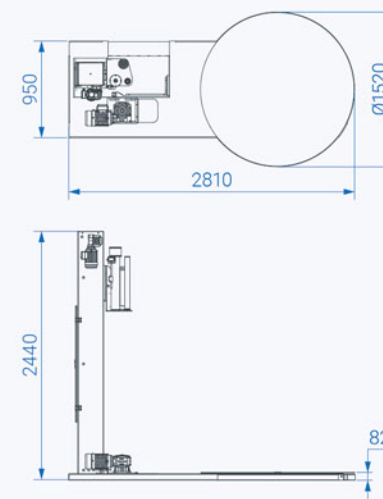

Machine Size	Turntable Dia.	Turntable Height	Optional	Applicable Film
機械尺寸	轉盤直徑	轉盤高度	選配	適用膠膜
L2820 × W1520 × H2440 mm Spec. subject to change without prior notice. 機台尺寸以實際製作為準	1500 mm Optional: Customized size is available. 可訂製加大	82 mm	Ramp 斜拖板	PE 20~30μ
Max. Load Weight	Max. Wrap Height	Film Carriage Speed	Turntable Speed	Voltage
乘載重量	裹包高度	昇降速度	轉盤速度	電壓
1500 kg Optional: 2000 kg 可選購：2000 kg	2000 mm	3 M/min Adjustable. 可調	12 RPM Adjustable. 可調	1Φ, 220V Depend on customer's request. 可依客戶需求指定